

Pro Pool PLUS

UV + Hydroxyl Radical Pool Sanitiser

Installation & Operating Manual



Vulcan

Important Notes

Congratulations on purchasing the Pro Pool PLUS UV + HO pool sanitising system, the latest in UV technology, manufactured in England to the highest standards.

To ensure your new product will give years of trouble free service **please carefully read the following instructions.**

Incorrect installation will affect your warranty. Do not discard this manual, please retain for future reference.

Important safety information

- Consult a qualified electrician
- Never look directly at an illuminated UV lamp
- Do not run this unit dry, do not cover this unit
- Always isolate the unit from mains electricity and turn off the water supply before carrying out maintenance
- Always disconnect all pool appliances from the mains electricity supply before servicing
- Power must be supplied through a Residual Current Device (RCD) with a rated residual operating current not exceeding 30mA
- This unit must be earthed. Never use a higher rated fuse than specified
- The unit must not be submerged in water
- If the quartz sleeve is cracked, replace it immediately
- Young children should always be supervised near water

Specification

Model: V-PP2-55 & V-PP2-110 (Analogue); V-PP3-55 & V-PP3-110 (Digital)

Rating: 220~240V 50/60Hz; 110~120V 50/60Hz

MAX Pressure = 3 Bar

This unit is manufactured in conformance with:

Safety: BS EN 60335-1:2002. BS EN 60335-2-55:2003

EMC: EN 55015: 2000. EN 61000-3-2: 2000 EN 61000-3-3: 1995.

EN61547:1995

This unit is CE approved.

Product Overview

The Pro Pool PLUS is available in 55W single tube and 110W double tube formats, supplied complete with flow switch and either an analogue lamp life indicator and reset switch, or digital lamp life countdown with intelligent dosing pump.

55W Single Tube Unit

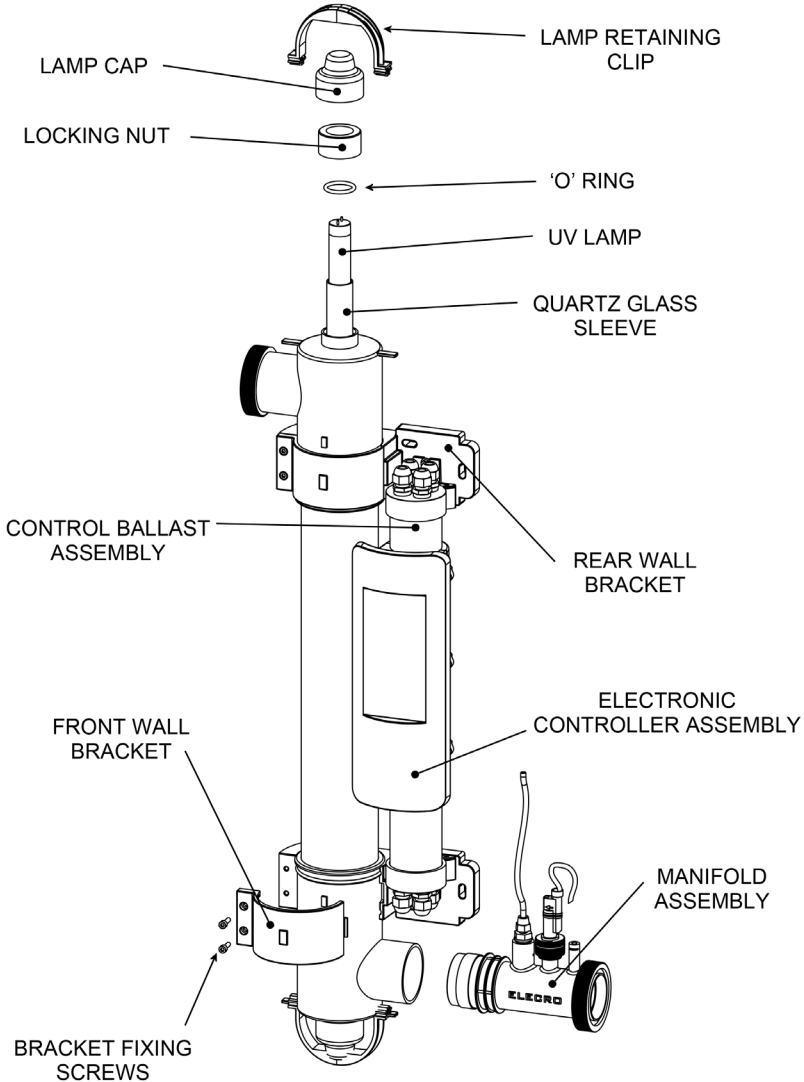

Note: Digital Model Shown

Fig 1.

110W Double Tube Unit

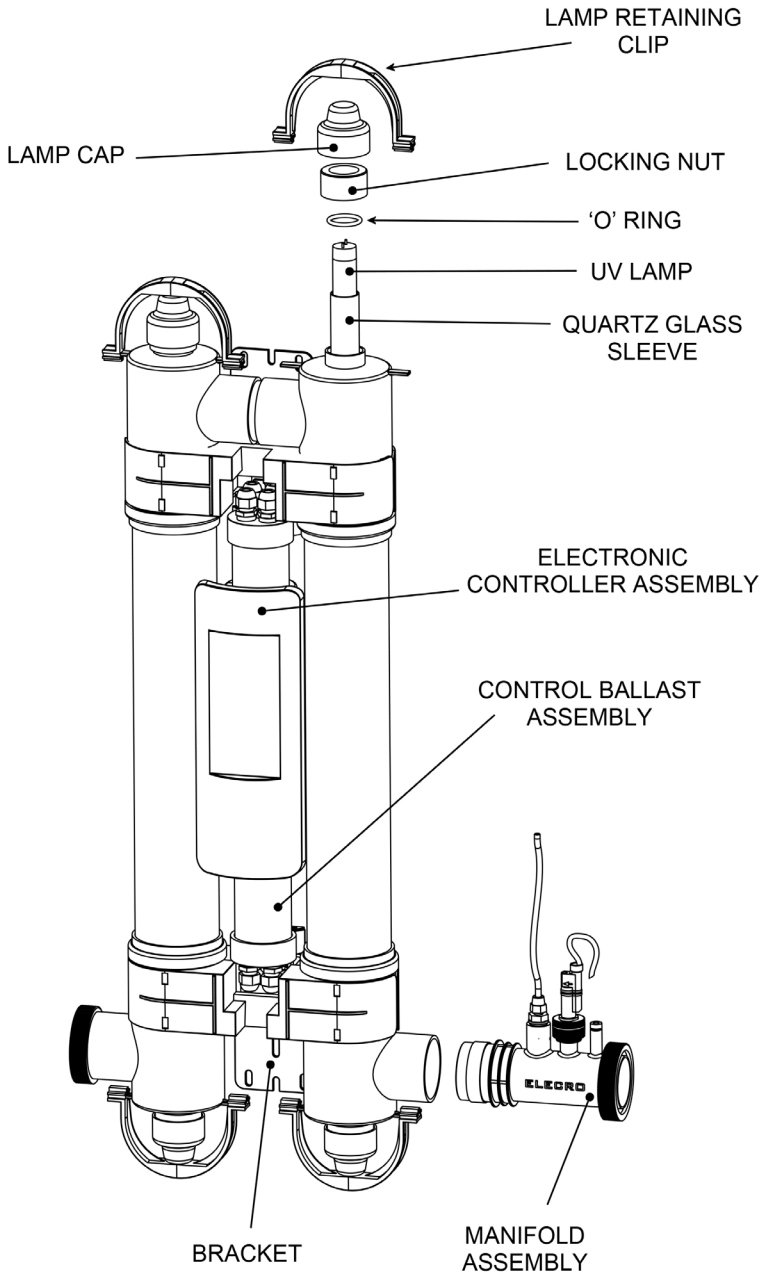

Note: Digital Model Shown

Fig 2.

Positioning the Unit

CAUTION: To prevent this unit falling into water, do not install above or alongside your pool.

The Pro Pool PLUS unit is weatherproof but not waterproof; it must be installed in a dry weatherproof enclosure. The unit must be mounted on a flat vertical surface horizontally or vertically. It must not be submerged in water or placed in a position where water may collect around the unit.

To prevent the unit inadvertently being dropped into the pool, the unit must be installed at least 3.5 metres from the edge of the pool.

The unit must always be plumbed into the water system after the filter as shown in fig 3. to prevent dirt and debris being pumped into the unit.

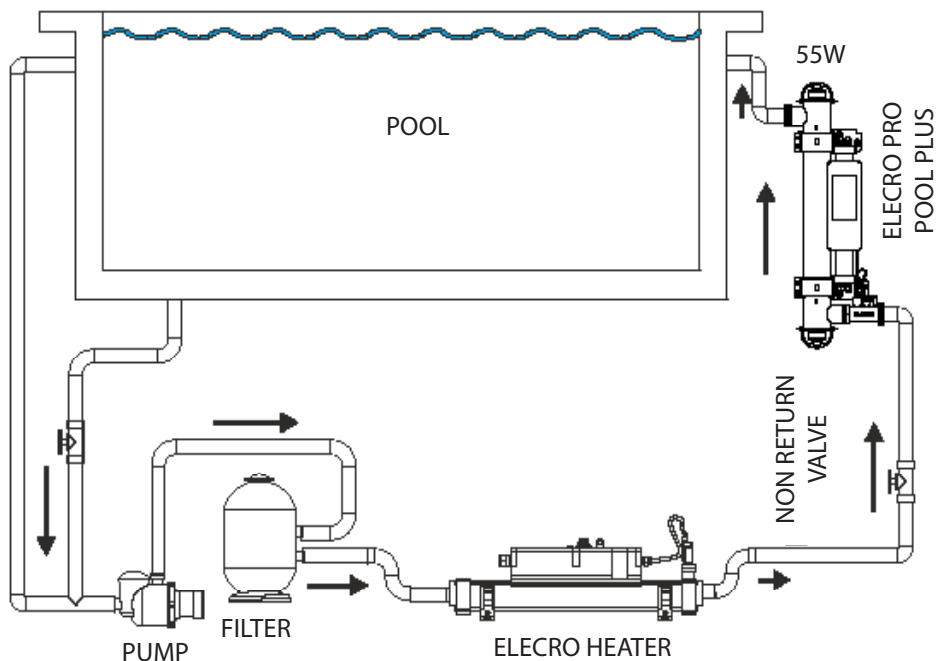

Fig 3.

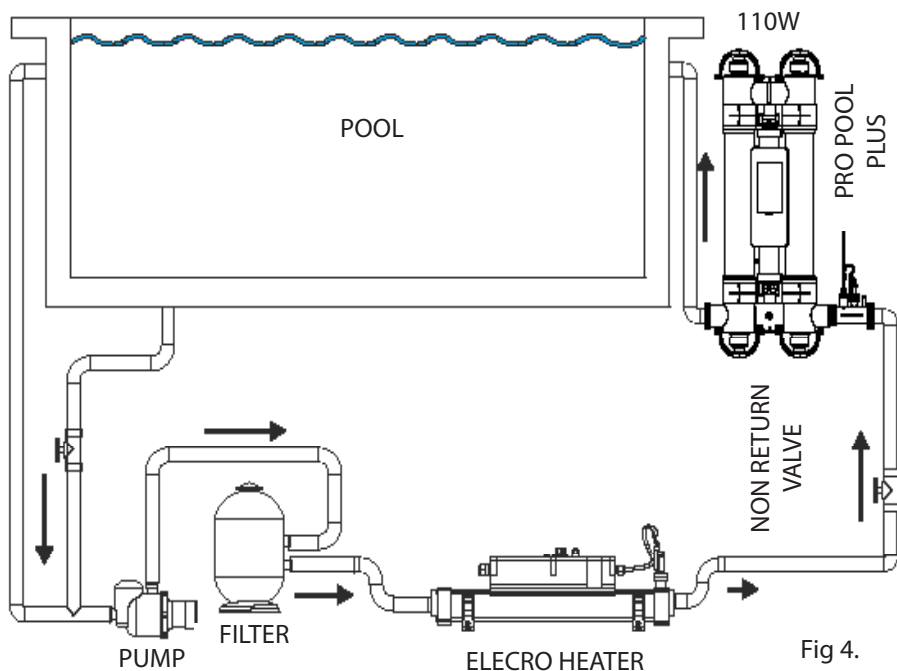

Fig 4.

Mounting the UV Unit

The unit may be mounted on a wall or other suitable vertical surface that is structurally strong enough (for example: when full of water the unit is too heavy to mount onto a conventional wooden fence panel). The unit is supplied with a fixing kit. The unit can be mounted vertically as shown in the next pages in fig 5. and 6. or horizontally as shown in fig 7.

NOTE!

When mounting the UV it is essential to leave a clearance space of at least 1 metre from one side of the unit to allow access to replace the lamp(s) and/or quartz sleeve(s) when required. Both the lamps and the quartz sleeve can be replaced from either end of the unit; if installing vertically the 1 metre clearance space must be above or below the unit, if installing horizontally the 1m clearance space must be to the left or right of the unit.

55W Single Tube Unit

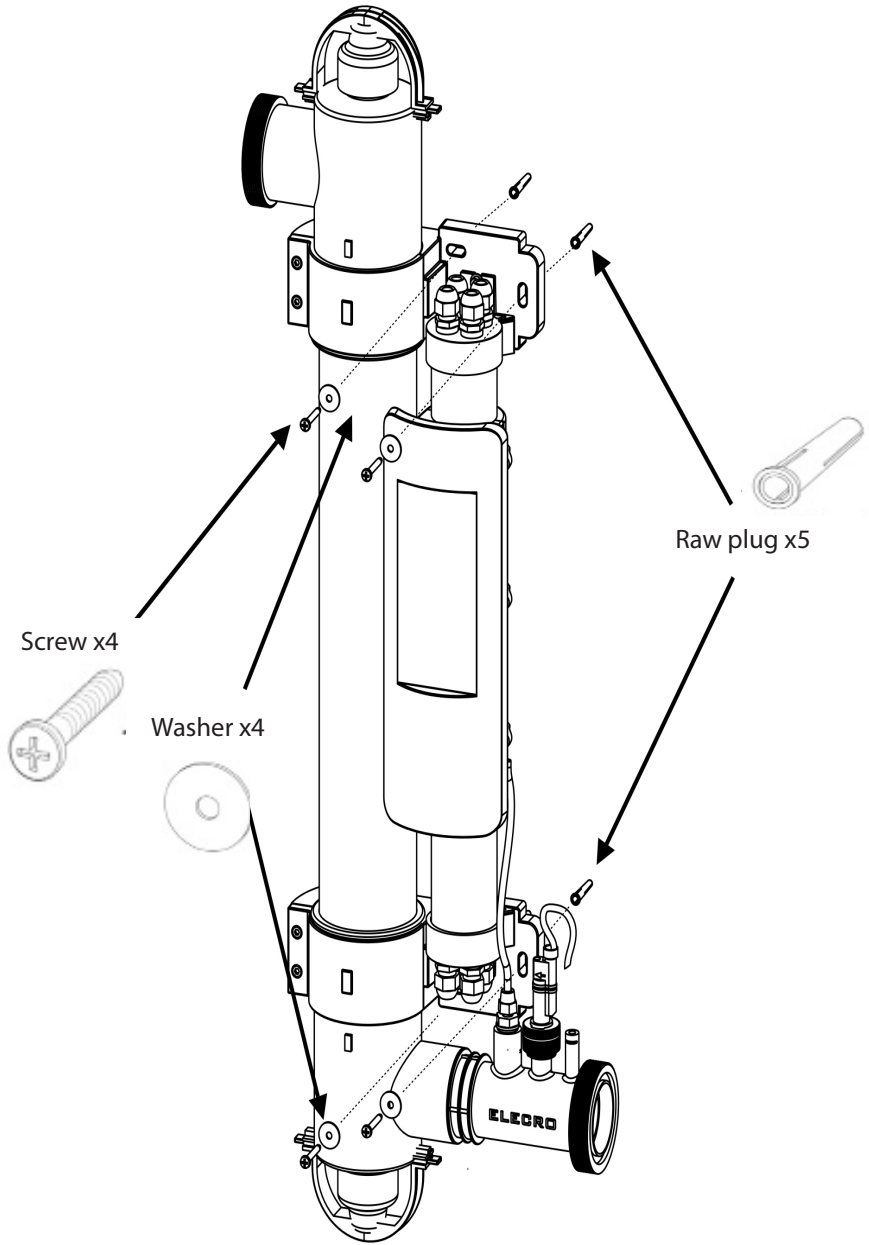

Fig 5.

110W Double Tube Unit

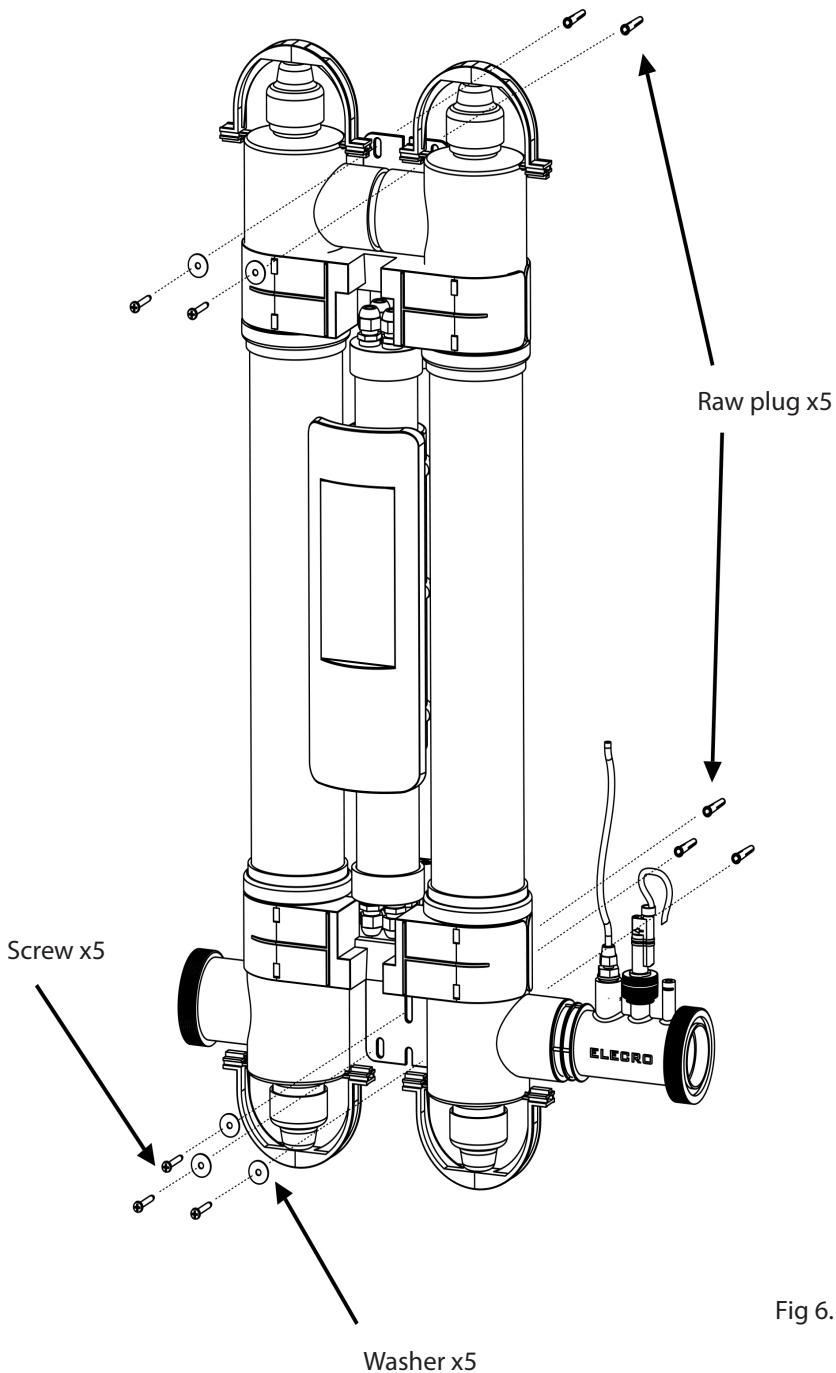
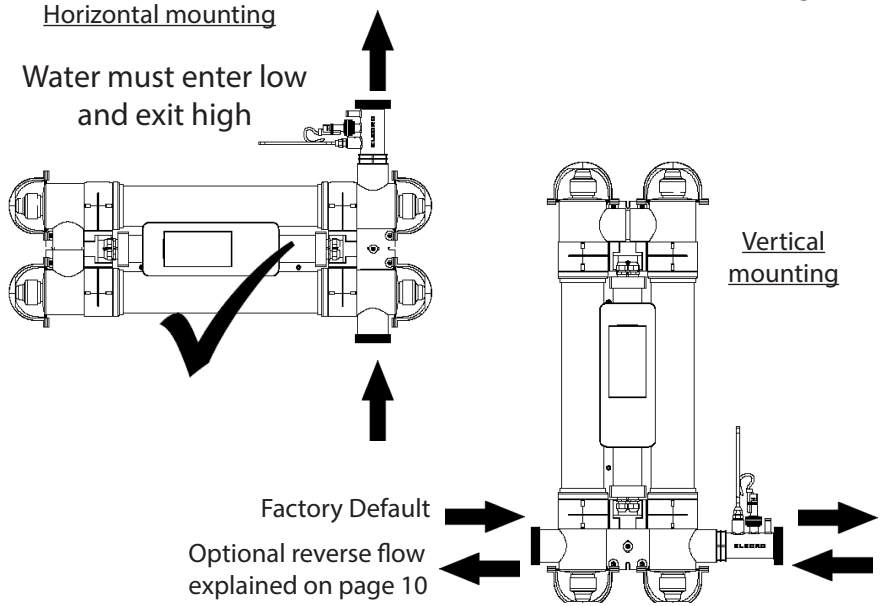

Fig 6.

110W Double Tube Unit

Fig 7.



55W Single Tube Unit

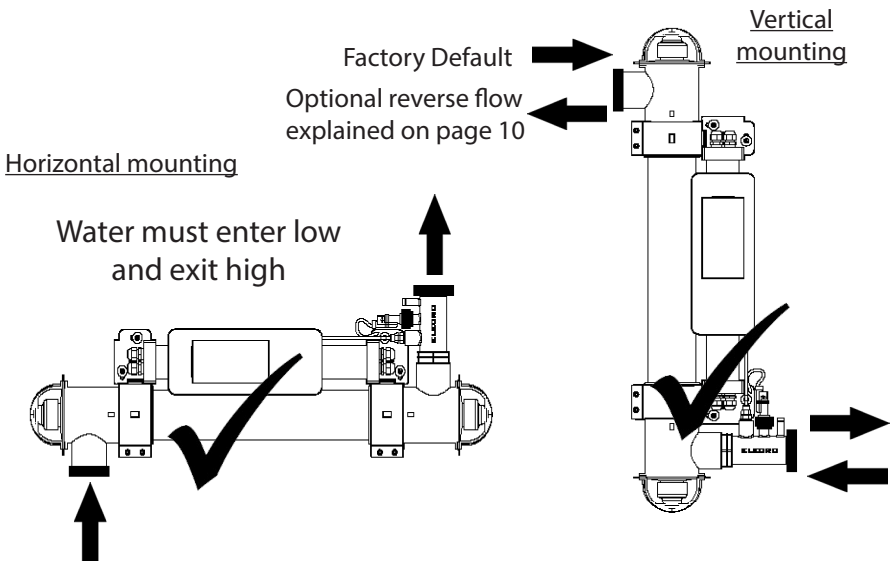

Connection to the water supply

The unit is supplied with unions to allow connection to 2" or 63-mm rigid pipe. Reducers are also supplied to allow connection to 50-mm or 1½" rigid pipe - see fig. 8.

For connection to 63-mm or 2" diameter pipe

Fig 8.

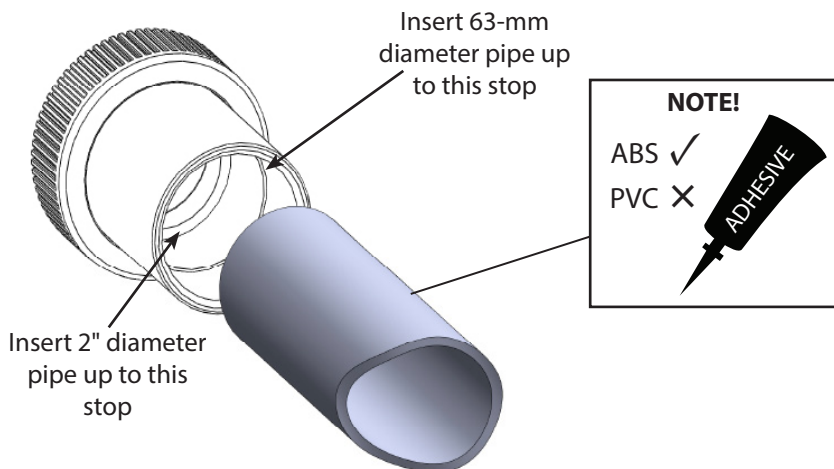

For connection to 50-mm or 1½" diameter pipe

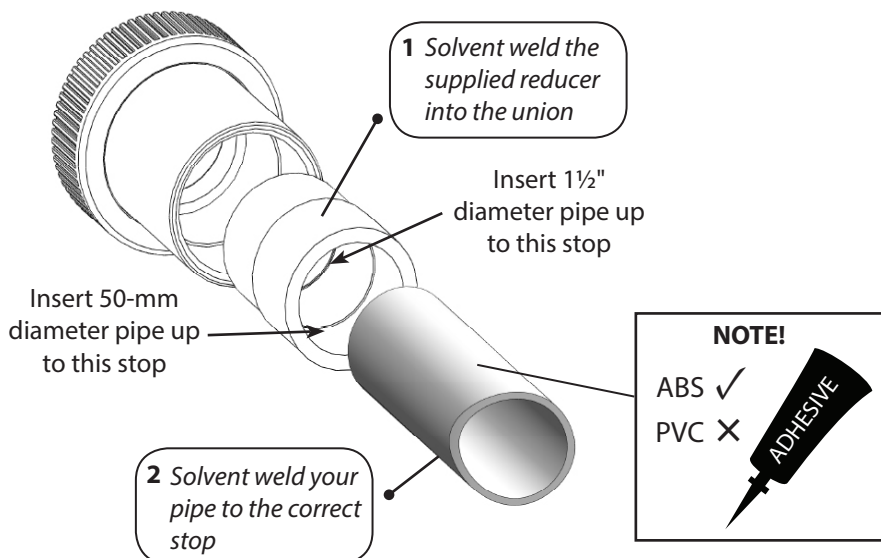

Flow Requirements

Minimum flow rate:

55W (single tube) and 110W (double tube) = 4m³/hour
(4,000 litres per hour)

Maximum flow rate:

55W (single tube) = 12m³/hour (12,000 litres per hour)
110W (double tube) = 24m³/hour (24,000 litres per hour)

Your Pro Pool PLUS is factory set to accept input water flow entering on the left and exiting on the right, this can be reversed by rotating the flow switch 180 degrees (i.e ½ turn - see fig. 8)

WARNING! The flow switch paddle can be damaged when reversing the flow direction if it is lifted by more than 5mm from its housing and turned with force. If the flow switch has been rotated it is important to ensure that it is finally locked in the correct orientation perpendicular (at right angles) to the flow of water.

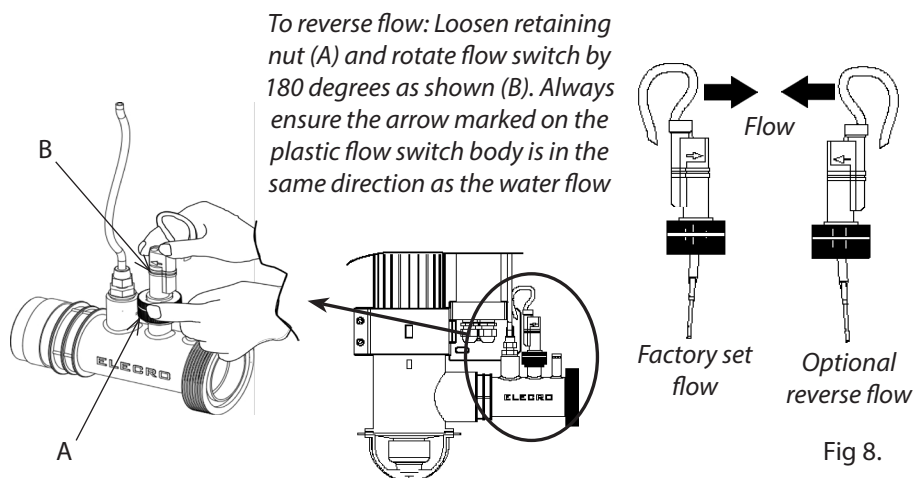

Electrical connection

The unit must be installed in accordance with the country / regional requirements and regulations. Always disconnect all pool appliances from the mains electricity supply before servicing. In any event the work must

be carried out by a qualified electrician, who will provide a certificate of conformity upon completion of the work.

The power supply must be fitted with a RCD with a rated residual operating current not exceeding 30mA. This unit must be installed inside a dry, weatherproof enclosure.

The unit is fitted with 5 metres of power cable. To prevent the unit inadvertently being dropped into the pool it must be securely positioned at least 3.5 metres from the edge of the pool.

Lamp Life Indicator Model (Analogue)

Under normal conditions the UV lamp(s) inside the unit have a usable life of 9,000 hours. The unit is fitted with a 'Lamp Life Indicator' LED in order to remind you to change the lamp(s) after this set period of time.

At initial 'Power On' of the Pro Pool Plus the LED indicator will light in Red colour for one second to indicate that the time setting is 9,000 hours, and immediately change colour to Green to indicate that the timer has started.

When the timer reaches <500 hours the LED indicator will change colour from Green to Amber to indicate that the UV lamp(s) is getting near to its end of life; when the timer reaches zero the LED indicator will change colour from Amber to Red, flashing slowly to signal that the UV lamp(s) should be changed.

After changing the UV lamp(s) the timer is reset by pressing and holding the reset button until the LED indicator goes 'Off' and then comes back 'On.' When the reset button is released the LED indicator will come back 'On' (Red colour for one second followed by Green colour), this indicates that the timer has restarted and is reset to count down the subsequent 9,000 hours.

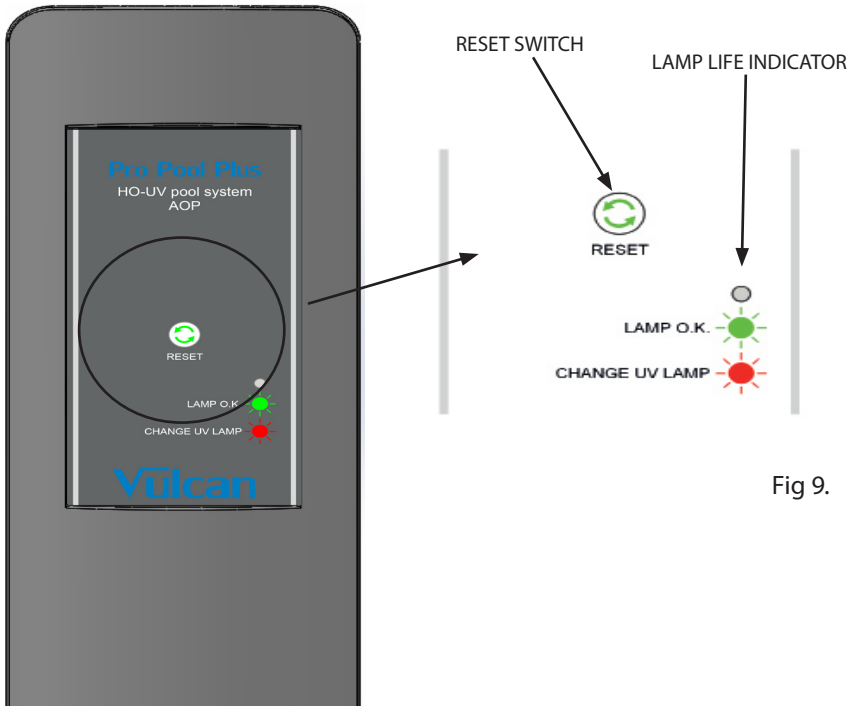
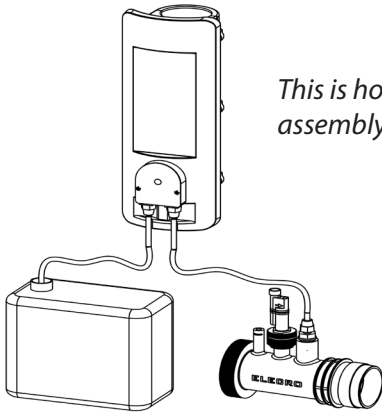

Fig 9.

Lamp Life Indicator + Intelligent Dosing Pump (Digital)

How to connect the suction tube to the dosing pump:



This is how the completed assembly will look

STEP ONE

Components required:

Foot Valve
Strainer



Tubing

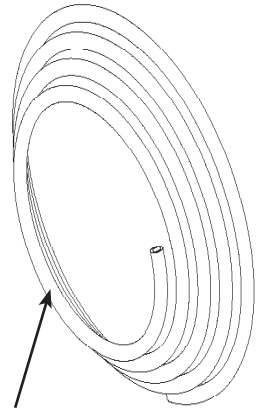

STEP TWO

Unscrew securing cap
anti-clockwise

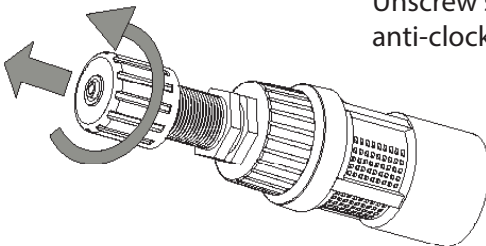

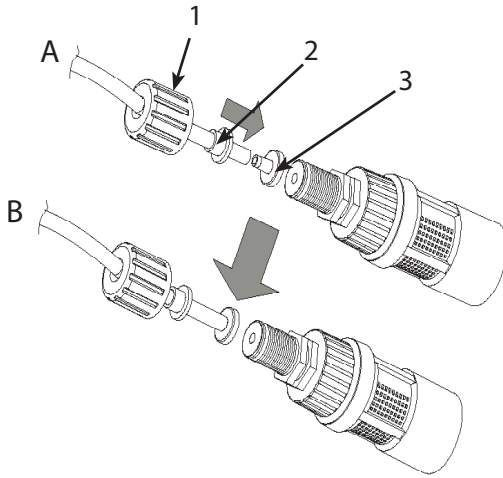
**STEP THREE**

Thread tube through the securing cap (1) and component (2), then push the pipe onto component (3)

STEP FOUR

Once all components are looped through the tubing tighten securing cap

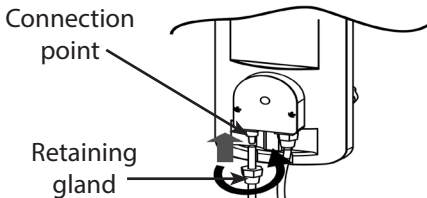
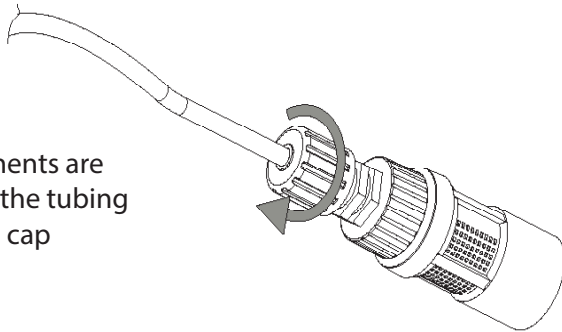
**STEP FIVE**

Lastly unscrew the retaining gland and insert tube over the connection point. Tighten the retaining gland

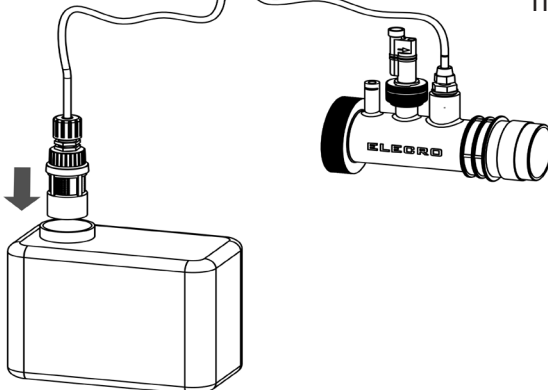

Place the Foot Valve Strainer into the chemical container

Fig 10.

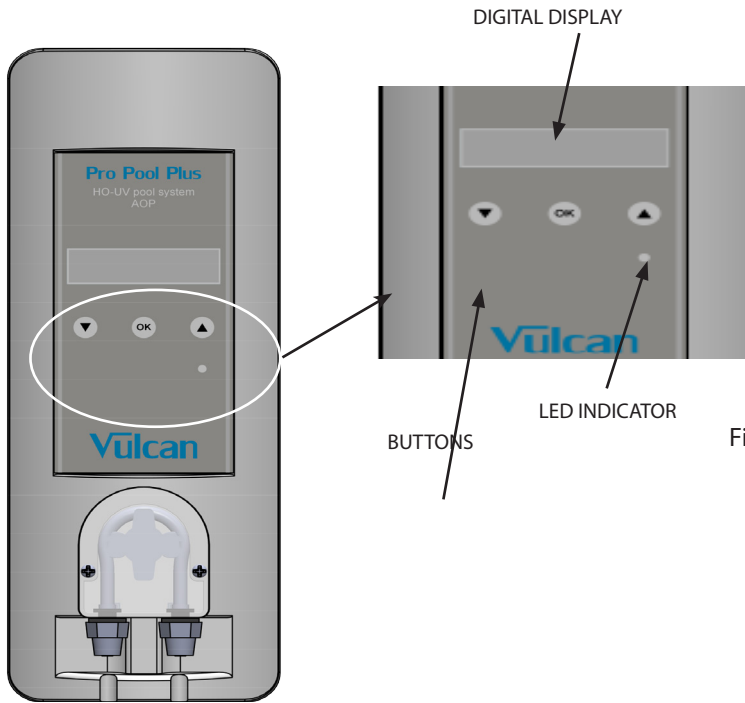



Fig 11.



Fig 12.

The language menu is displayed on each power up of the unit.

The factory default setting for the language is English.

To change to another language, press the  /  buttons until the desired language appears, press OK to select and save.

The digital controller has four programmable functions:

- UV Lamp Life
- Shock Dose
- Dose Chemical
- Set Time

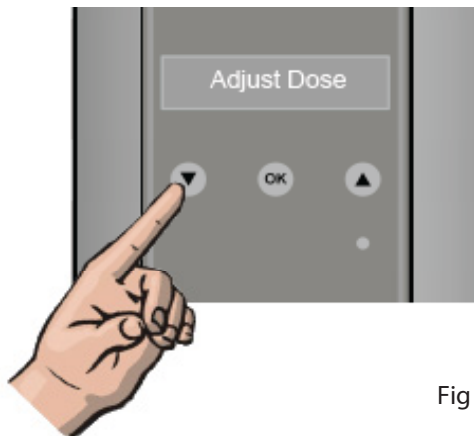

Fig 13.

To select a mode press the ▲ / ▼ buttons until the desired mode is displayed then press the OK button to select that mode.

Operation:

When the unit is powered on the UV lamp is switched on, the UV lamp will switch off under the following conditions ie:

- Dosing pump 'On' (and for 30 minutes after the dosing pump has completed dosing)
- No or low water flow (the UV lamp(s) cannot be switched on unless the unit is receiving sufficient flow) See page 10 for flow requirements.

UV Lamp Life:

Fig 14.

Whenever the UV lamp is 'On' a timer counts down from 9,000 hours and the remaining UV lamp life is displayed.

From 9,000 hours to 500 hours the LED in the control panel will light in green. When 499 hours is reached the LED colour will change to amber, when 0 hours are reached the LED light will change to red indicating that the lamp(s) must be changed.



When the UV lamp(s) are replaced the lamp life timer must be reset to 9,000 hours. In the UV lamp life mode select 'Reset UV Lamp' by pressing and releasing the O.K. button, then immediately press and hold the O.K. button until the display shows 'SAVED' then release the O.K. button, the display will then show 'UV Life 9,000 Hrs' Please note power failure does not affect this lamp life countdown.

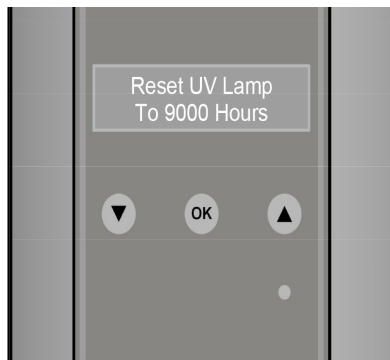

Chemical Dosing Set-Up:

The controller is pre-programmed to dose two chemical types:

- A.) Hydrogen Peroxide / Active Oxygen / H₂O₂
- B.) Liquid Chlorine

Part 1

To set the type of chemical: use the ▲ / ▼ buttons until "DOSE CHEMICAL" is displayed, press the O.K. button and then use the ▲ / ▼ buttons to choose:

- A.) 'H2O2' or
- B.) 'CHLORINE'

Press the O.K. button to select

A. Dosing Hydrogen Peroxide (H₂O₂):

After selecting 'H2O2' in Part 1 the display will now show 'H2O2 DOSE' using the ▲ / ▼ buttons select the correct dosage volume in ml (millilitres) – Refer to table A for suggested H₂O₂ dosing figures.

Once the correct dosage volume is displayed press the O.K button to confirm, the display will then show 'H2O2 START'

You now need to enter the time that you would like the dosing to take place – **NOTE:** the time must be entered in the 24-Hour format and the dosing will take place at this time every day (24-Hours).

NOTE: The time selected must be at a time when the main filtration pump will be running.

Once the desired time has been selected press the 'O.K.' button and the display will then show 'SAVED'.

NOTE: If the dosing volume is set to 0.0 (ml) the peristaltic pump will remain off.

NOTE: In the event of power loss: the programmed settings (dosing volume and dosing time) will remain stored. If the power to the controller is switched off for longer than 3-Hours the current time will need to be re-programmed, this is indicated to the operator by the clock flashing.

Set Dosage Requirements:

Please note: Dosage amounts are set in ml/day (millilitres per day)
Use the below reference table as a guide.

To calculate your pool volume see page 26-27 at the rear of this manual.

| Volume of swimming pool (m ³) | Dosing amount (ml/day) |
|---|------------------------|
| 35 | 200 |
| 50 | 320 |
| 60 | 420 |
| 80 | 620 |
| 90 | 700 |
| 100 | 800 |
| 130 | 1040 |
| 150 | 1200 |

NOTE: The above table is based on dosing Hydrogen Peroxide (H₂O₂) with a 32% concentration and a water temperature of 28°C.

For a concentration of 12% the above dosing amount should be multiplied by 3 (i.e. the dose for a 50m³ pool would need to be increased to 960ml/day when the H₂O₂ strength is 12%).

For any other concentration strengths, the dose amount should be adjusted pro-rata as required. The digital controller will automatically sense the temperature of your water and adjust the required dose accordingly.

B. Dosing Liquid Chlorine

Refer to table B for suggested Liquid Chlorine dosing figures.

NOTE: When dosing with liquid chlorine the daily dosage amount should be halved to enable half the dose to be delivered in the morning (CL 1 DOSE) and half the dose to be delivered in the afternoon (CL 2 DOSE).

NOTE: The controller does not monitor the free chlorine level. The pool free chlorine levels must be regularly checked and the dosage volume adjusted if required.

After selecting 'CHLORINE' in Part 1 the display will show 'CL 1 DOSE' using the ▲ / ▼ buttons select the correct dosage volume in ml (millilitres). Once the correct dosage volume is displayed press the O.K button to confirm, the display will then show 'CL 1 START'

You now need to enter the time that you would like the CL 1 dosing to take place. Once the correct time is selected press the 'O.K.' button.

The display will then show 'CL 2 DOSE' you now need to repeat the above process to programme the CL 2 DOSE (volume) and CL 2 START (time).

NOTE: the time must be entered in the 24-Hour format and the dosing will take place at this time every day (24-Hours).

NOTE: The time selected must be at a time when the main filtration pump will be running.

NOTE: It is recommended to keep the dosage volumes in equal halves, however should you need to adjust to have a larger proportion during the CL 1 or CL 2 periods then this can be programmed accordingly, if you only wish to use one of the dosing periods then this is also possible.

NOTE: If the dosing volume for both CL 1 and CL 2 periods is set to 0.0 (ml) the peristaltic pump will remain off.

| Volume in Litres | Stabilised Liquid Chlorine (ml) |
|------------------|---------------------------------|
| 10.000 | 200 |
| 20.000 | 400 |
| 30.000 | 600 |
| 40.000 | 800 |
| 50.000 | 1000 |
| 60.000 | 1200 |

Table B

Dosage is only approximate and dependant on the exact volume of your pool, local water type, temperature, positioning of the pool, bather loading weather, etc.

NOTE: In the event of power loss: the programmed settings (dosing volume and dosing time) will remain stored. If the power to the controller is switched off for longer than 3-Hours the current time will need to be re-programmed, this is indicated to the operator by the clock flashing.

Set Current Time:

To complete the set up you need to programme the current time: Use the ▲ / ▼ buttons until 'SET TIME' is displayed, Press the O.K. Button.

Use the ▲ / ▼ buttons as required to select the current time

NOTE: the time must be entered in the 24-Hour format.

The display will now revert to showing the UV lamp life remaining and the current time.

Shock Dose:

The shock dose feature enables the operator to shock dose the pool immediately with a chosen volume of the dispensing chemical. This may be necessary following heavy use of the pool or a change of water conditions.

To activate the Shock Dose feature use the ▲ / ▼ buttons to scroll until 'SHOCK DOSE' is displayed, press the 'O.K' button.

Using the ▲ / ▼ buttons select the volume (in ml / millilitres) that you would like to shock dose the pool with. When the correct value is shown, press the 'O.K. button to confirm. The display will show 'SAVED' and the shock dose will begin **immediately.**

NOTE: The shock dose will only begin if the main filtration pump is operational.

Intelligent Dosing Pump Routine Maintenance

We recommend that the dosing tube is changed every 12 months in order to prevent any wear and tear and keep performance to an optimum. The following steps will guide you how to replace the dosing tube:

STEP ONE

Unscrew the two screws securing the plastic cover and remove. Rotate the grey connection caps to release the tubing.

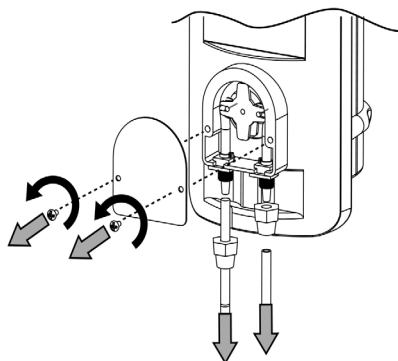

STEP TWO

Remove the connection point on the left hand side, and then carefully manually rotate the cam to allow removal of the dosing tube.

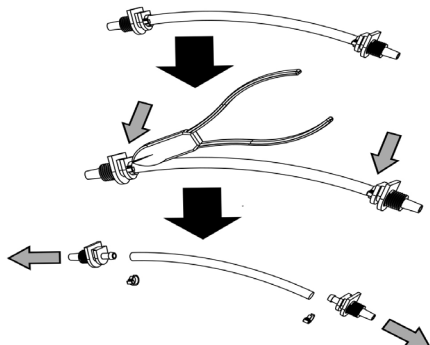
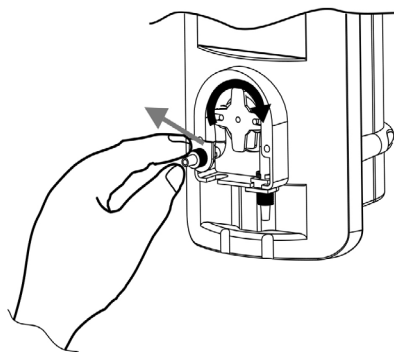

STEP THREE

Cut the two black securing ties at either end of the tube. This will then release the tube, which can be discarded.

STEP FOUR

Take the replacement tube and re-attach connection points. Loop securing ties in place in order to seal to the connection points. Once securely in place cut the excess tie and dispose of.

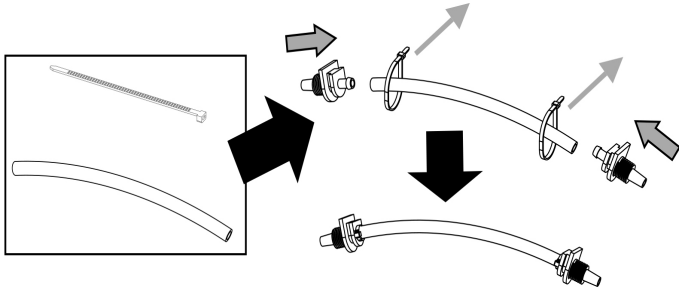
**STEP FIVE**

Place dosing tube into position on the left-hand side. Carefully rotate the cam clockwise, whilst feeding the pipe back into place.

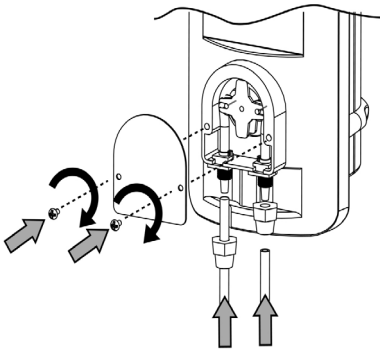
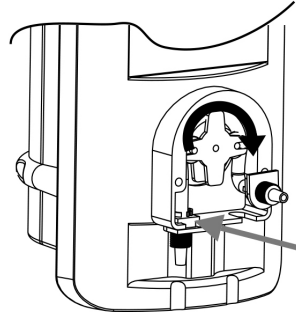
**STEP SIX**

Replace the suction and output tubes onto connection caps, and rotate to secure tubing back into place. Replace clear cover and screw into position.

Frost Protection

It is essential that the unit is protected from frost during the winter months, or disconnected from the water and electricity supply and stored inside a dry weather proof enclosure.

Lamp Replacement & Quartz Glass Cleaning (all models)

Isolate from the electrical and water supplies before carrying out any maintenance.

Lamp Holder restraint: A plastic lamp holder restraint is fitted at either end of each lamp chamber to prevent the lamp holders being accidentally removed while the unit is connected to the mains.

Each restraint is held in place with a self tapping screw. To carry out any routine maintenance these restraints must be removed, it is essential to re-attach them once the maintenance work has been completed. In time it may be necessary to replace the fixing screws (no.8 size screw) with a slightly larger screw.

To remove the lamp, carefully remove the blue lamp holder shroud, then pull the white plastic electrical end caps from the lamp end. Gently slide the lamp out ensuring that no pressure is applied to the glass quartz sleeve. Next, unscrew the two blue compression fittings located at either end of the main body and slide off the 'O' rings. Then slide out the quartz glass sleeve. Clean the sleeve and polish with a soft cloth or paper towel.

If you live in a hard water area there maybe some limescale on the quartz sleeve. This can be easily removed by soaking the sleeve in a proprietary kettle descaling solution (follow the manufacturer's instructions). Failure to remove the limescale will limit the effectiveness of the UV lamp(s).

Assembly process: Slide the clean, dry quartz glass sleeve into the unit. Ensure that you locate the 'O' rings carefully on the ends of the quartz. Failure to do so will result in leaks when the water is turned on. If you are carrying out the annual lamp change, use new 'O' rings. When you re-assemble the unit, ensure that the female threads on the compression fittings and the male threads on the main body are clean.

Wipe a little silicone grease or Vaseline (not silicone sealant) onto these threads. As these threads are only serviced periodically, this lubrication will help to prevent them binding together. Then refit and firmly hand tighten the compression fittings. Refit or replace the UV lamp(s) with a new one. Relocate the lamp holders and blue lamp holder shrouds ensuring that you match the correctly numbered lamp holder.

Note: Pinch the blue lamp holder shroud as you reassemble the unit to release any trapped air. Failure to release the trapped air may cause the lamp holder to disconnect from the lamp end. Reconnect and turn on the water supply to check for leaks before reconnecting the electric supply.

Important: The plastic body and blue compression fittings have been manufactured from polymers that have been specifically stabilised to protect them from the effects of the UVC emitted from the UV lamps. Despite this UV protection they will be eroded by a combination of the UVC and water flow. As a matter of course they should be inspected whenever a lamp change is carried out, to ensure they are not showing excessive wear and tear. Replacement parts are available.

RoHS Compliance Statement

Elecro Engineering Limited certify that our UV Pool sanitiser range complies in accordance with RoHS Directive 2011/65/EU on the restriction of hazardous substances.

Waste of Electrical / Electronic Equipment

This product complies with EU directive 2012/19/EU

Do Not dispose of this product as unsorted municipal waste.

This symbol on the product or on its packaging indicates that this product should not be treated as household waste. Instead it should be handed over to the applicable collection point for the recycling of electrical and electronic equipment.

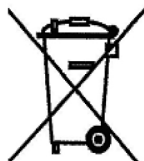

By ensuring this product is disposed of correctly you will help prevent potential negative consequences for the environment and human health, which could otherwise be caused by inappropriate waste handling of this product. The recycling of materials will help to conserve natural resources.

For more information please contact your local Civic office, your household waste disposal service or the retailer where you purchased the product.

Guarantee

Your Pro Pool PLUS pool sanitiser is guaranteed for 2 years from the date of purchase against faulty workmanship and materials.

The manufacturer will replace or repair, at it's discretion, any faulty units or components returned to the company for inspection.

Proof of purchase may be required. The manufacturer will not be liable in cases of incorrect installation of the product, inappropriate use, or neglect.

This guarantee does not include serviceable parts, ie: lamps, quartz sleeves, dosing tubes and o-rings, etc.

Calculating Pool Volumes

The following pages will show you how to calculate the volume of your pool.

NB For pools with different depths:

$$\frac{D1 + D2}{2} = \text{Average Depth}$$

If your pool has a sloping bottom, then take the deepest measurement (D2) and the shallowest (D1). If there are different levels, then you need to do several calculations of area for each depth and add them up at the end.

Rectangle & Square Pools

$$\text{Volume} = \text{Length (L)} \times \text{Width (W)} \times \frac{\text{Depth (D)}}{\text{Average Depth}}$$

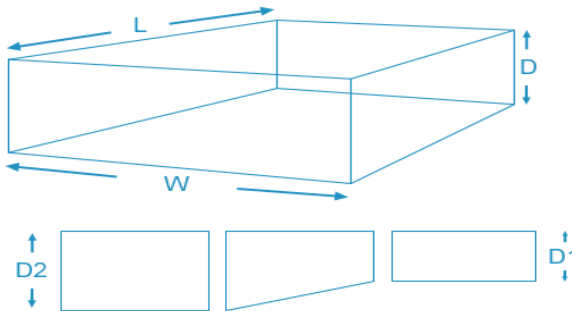

Circular

$$\text{Volume} = \pi (3.142) \times \text{Radius}^2 \times \frac{\text{Depth (D)}}{\text{Average Depth}}$$

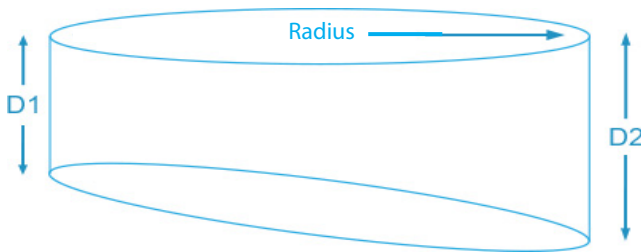

Radius = Diameter divided by 2

Ellipses

$$\text{Volume} = \pi (3.142) \times A \times B \times \frac{\text{Depth (D)}}{\text{Average Depth}}$$

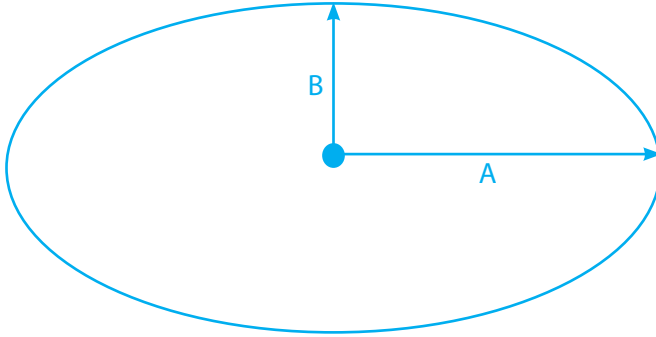

Irregular Shapes

For irregular shapes, calculating the area is less accurate. You will need to draw up the pool accurately to scale on graph paper using a square on the paper to represent a metre (or foot) square of pool. When you have finished, count the squares.

For partial squares, count anything over half as one and ignore any under a half. When you have the area (A) multiply by depth (D) for the Volume in cubic metres. If you have several depths, break up your area calculation for each depth.

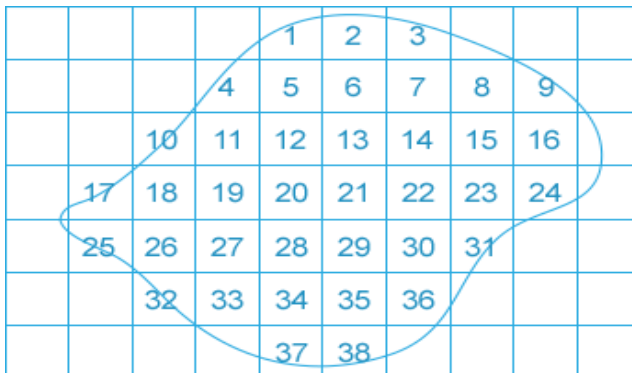

Useful Conversions

Cubic Metres to Litres = Multiply by 1000

Cubic Feet to Cubic Metres = Multiply by 0.0283168

UK Gallons to Litres = Multiply by 4.54609

Litres to Cubic Metres = Multiply by 0.001

Cubic Metres to UK Gallons = Multiply by 219.969

Vulcan

11 Gunnels Wood Park | Stevenage | Hertfordshire | SG1 2BH | United Kingdom

t: +44 (0) 1438 749 474 | **f:** +44 (0) 1438 361 329 | **e:** sales@elecro.co.uk

www.elecro.co.uk